

FUEGO



Most designers wouldn't dream of playing with fire. Fortunately, we're not most designers.

Where Revolution Trumps Evolution

Attaching a label to Fuego is trickier than throwing a salmon—wild, rubbed with herbs and spices—on an open flame. Yes, it's a grill. But it's also an outdoor entertainment center. A social magnet with a great sense of style. The envy of every piece of outdoor furniture you own. Vibrantly designed with enough technological innovations to satisfy the most left-brained among us, Fuego represents a modernist rethink of outdoor living. Which, for people who prefer their aesthetics well done, is a concept worth embracing.





Fuego 01: Four Sides of the Story

What you see—and what you don't—is an architectural reinvention of outdoor grilling. A fully retractable lid. Countertops wide enough for food, glasses and elbows. Heavy-duty storage areas tucked out of sight. Multiple fuel options. Smooth-wheeling agility. Fuego 01 delivers it all. And then some.



Front



Top



Fuego 01: Make Room for Modernism

While we've done everything possible to win a place in your heart, let's make sure you actually have room for us.

Burner options

2 standard gas drawers 37,000 BTU/hr. FG01AMG

Optional infrared drawer 18,500 BTU/hr.* FA01AID

Optional charcoal drawer* FA01ACD

Natural gas conversion available* FA00AGC

Features

Patented quick change drawer system

Multiple fuel options

Fully retractable lid

Teak and slate countertops with hidden storage

Modular accessory system

Two sliding drawers for propane tank and storage

Built-in residue trays

Battery ignition

Built-in wheels for easy mobility

Wheel brake

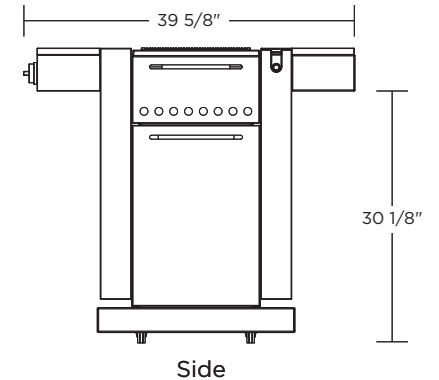
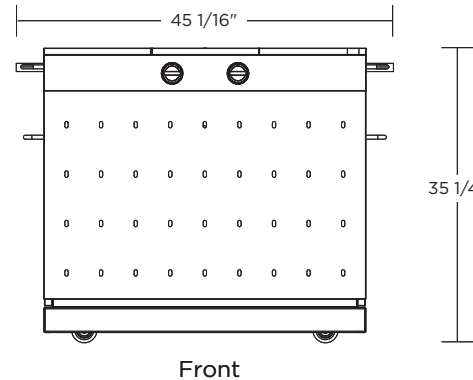
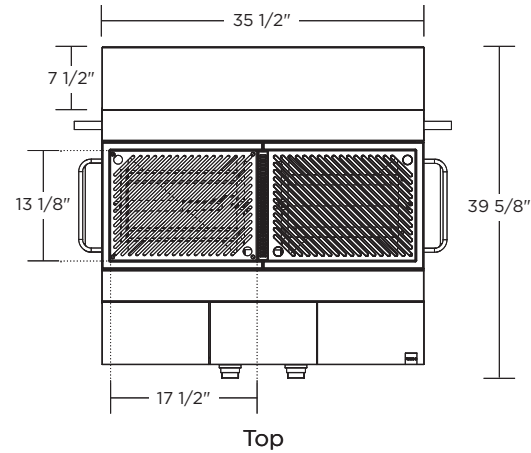

*Sold as accessory

Specifications are subject to change without notice. Please call 888.88.FUEGO or check our website at www.fuegoliving.com for potential specification updates.

Fuego 02: Squaring Off the Possibilities

A scaled down interpretation of Fuego 01, Fuego 02 is available in gas or infrared and features many of the signature elements of its larger sibling.



Front



Top

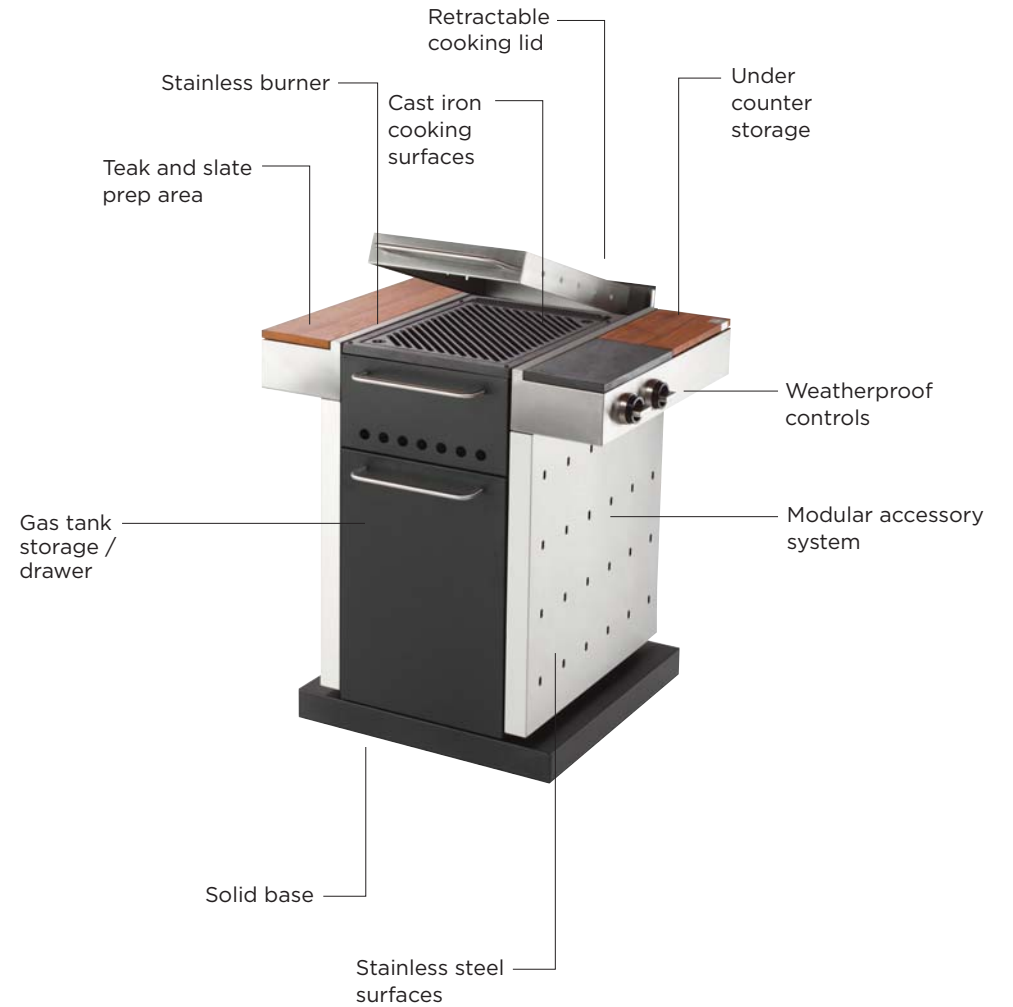

Fuego 02: Scaled to Size

Know the old adage that good things come in small packages? How true it is.

Burner options

Stainless gas burner 18,500 btu/hr. FG02AMG

Infrared burner 18,500 btu/hr. FG02AMI

Natural gas conversion available* FA00AGC

Features

Fully retractable lid

Slate and teak countertops with under counter storage

Modular accessory system

Sliding storage/ tank drawer

Built-in residue tray

Built-in wheels for easy mobility

Wheel brake

*Sold as accessory

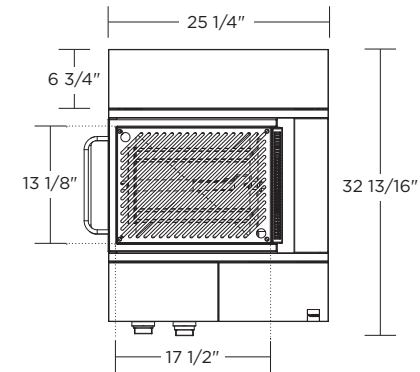

Top

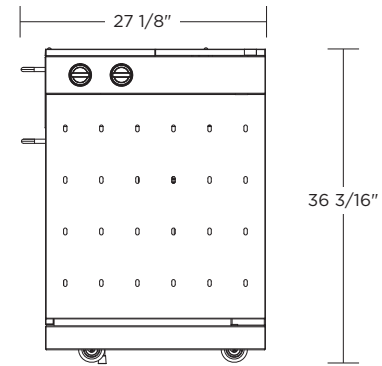

Front

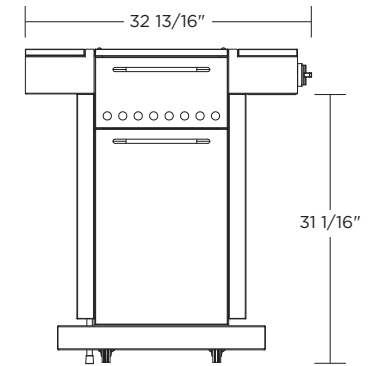

Side

Specifications are subject to change without notice. Please call 888.88.FUEGO or check our website at www.fuegoliving.com for potential specification updates.

Up Close

Like everything else in life, details matter. What you'll find with Fuego is modernism executed with the finest materials and technologies.



Gas Tank/Storage Drawers

Gone are the days of crawling under the grill to hook up a tank. One drawer slides out for easy propane tank storage, while the other can be used for stashing your outdoor cover or grilling tools. Want to use natural gas? No problem. We offer a natural gas conversion kit.



Natural Wood Prep Area

Teak countertops on both sides of the grill and a slate insert give the chef and guests enough work space to prep on site. Chop, stir and converse without having to dash back and forth to the kitchen for utensils and ingredients.



Patented Quick Change Drawer System

The Fuego 01 features a patented quick change drawer system, which comes standard with (2) gas drawers. The infrared and charcoal drawer options can be easily swapped out for hybrid cooking on the fly. Both the 01 and 02 grills have cast iron cooking surfaces for maximum heat retention and quality cooking.



Retractable cooking lid

Mountainous hood? What mountainous hood? Fuego has a fully retractable lid that glides into and out of the grill with ease, cleverly doing away with social barriers in seconds flat.

Revolutionizing High-Rise Living

With a modernist design aesthetic hot enough to sizzle imaginations along with two-inch thick steaks, Fuego 02 Electric takes high-rise grilling to a whole new level. Ideal for balconies and other outdoor spaces where open flames aren't an option, this all-electric grill is compact enough to tuck out of the way yet eye-catching enough to make a big statement. Add technological innovations, exceptional materials, unparalleled heating gusto and the kind of styling that gives million-dollar views a run for their money, and what you get is an inspired rethink of outdoor living.



Fuego 02 Electric: The Heat is On

Seasoned with enough bells and whistles to send conventional electric grills running for cover, Fuego 02 Electric takes modernism to the top. Teak and slate countertops with hidden storage areas. A removable cord for trip-free walking. A streamlined retractable lid. A convenient modular accessory system. They're all here and more.



Front



Top

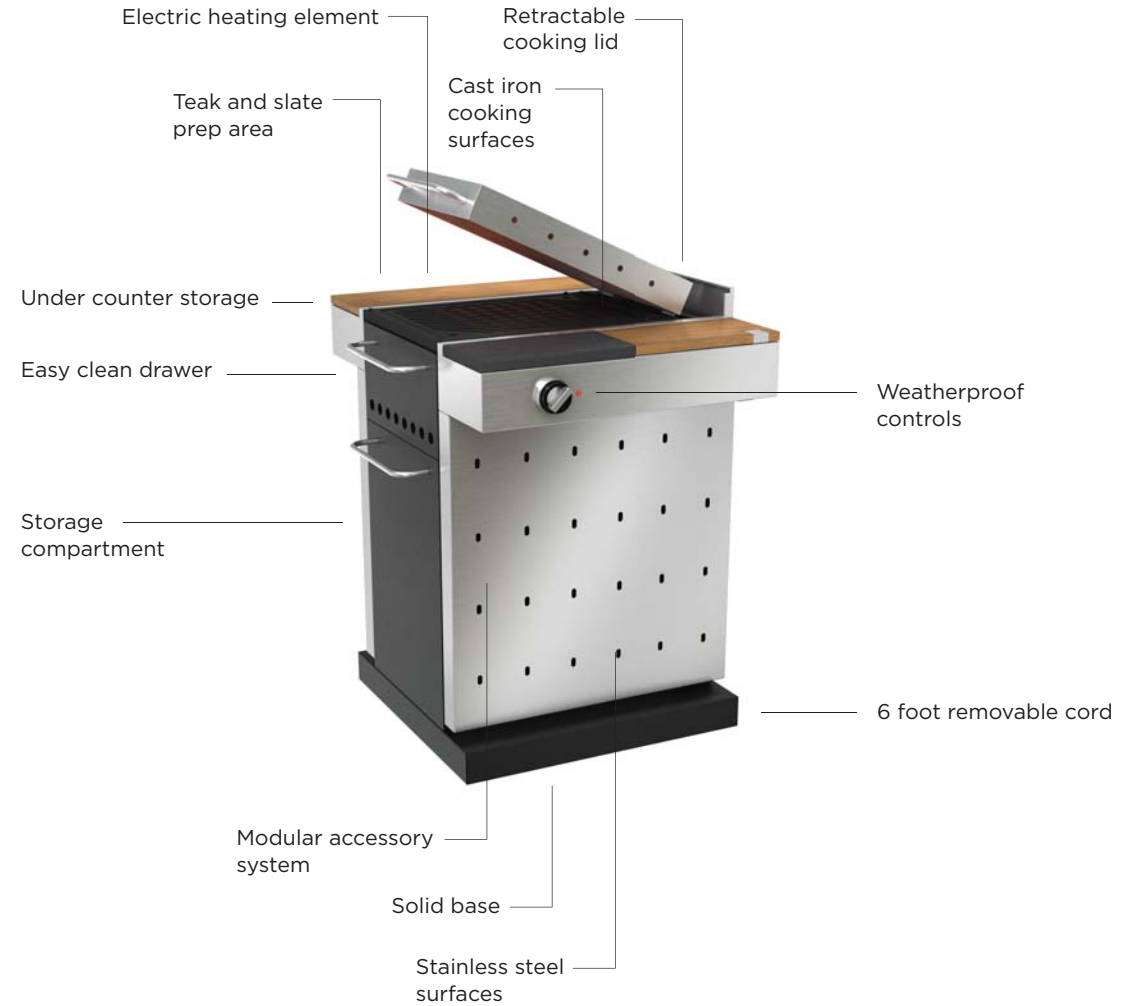

Fuego 02 Electric: Scaled to Size

No matter how tight your quarters, chances are you'll have space for this architectural reinvention of the electric grill.

Burner

Electric heating element

Power rated 1650W

Voltage rated 120V, 60HZ

Amps 13.75

Features

Fully retractable lid

Slate and teak countertops with hidden storage

Modular accessory system

Sliding storage drawer

Built-in residue tray

Cast iron, enamel coated grates

Easy clean removable drawer

6 foot removable cord

Built-in wheels for easy mobility

Flat plate*

Large cooking lid*

Outdoor cover*

Temperature Range

Low/high 150—700°F

*Sold as accessory

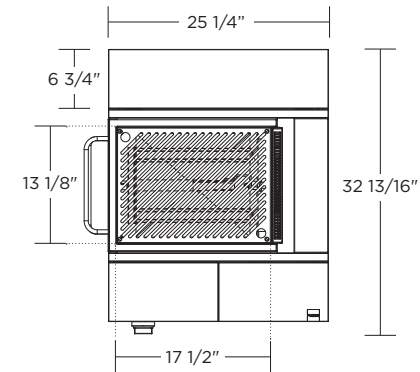

Top

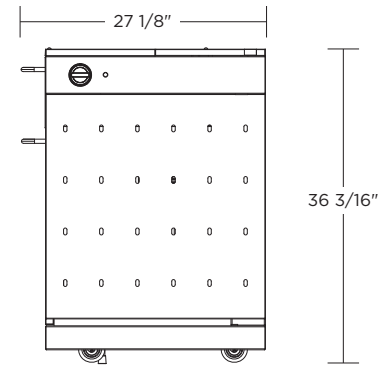

Front

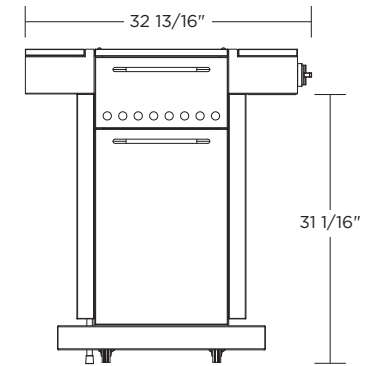

Side

Specifications are subject to change without notice. Please call 888.88.FUEGO or check our website at www.fuegoliving.com for potential specification updates.

Up Close

Take a close look at what makes Fuego O2 Electric a grill without equal.

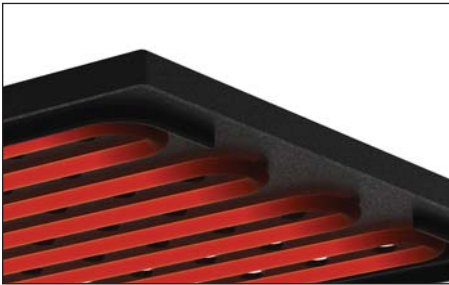

Custom Electric Element

In direct contact with the cast iron grill grate, our custom electric element provides maximum heat conductivity while eliminating grease flare-ups. A reflector plate located under the element radiates heat back to the grill surface to ensure the highest cooking intensity, providing both radiant and conductive heat.

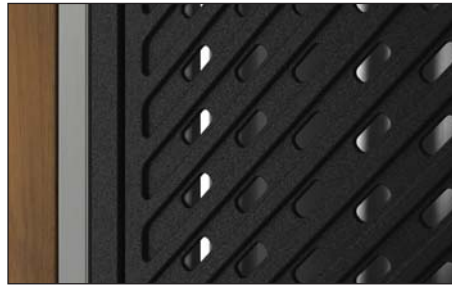

Cast Iron Grill Grate

Fuego O2 Electric is powerful enough to reach, maintain and evenly distribute temperatures of up to 700° F due in large part to the optimal heat retention characteristics of cast iron. The retractable lid aids in preheating the grill surface and can be used during cooking to maximize heat.



Easy Clean Drawer

Clean up is a breeze with our discrete, removable drawer and stainless steel and dishwasher safe residue tray, which slide in and out in a blink.

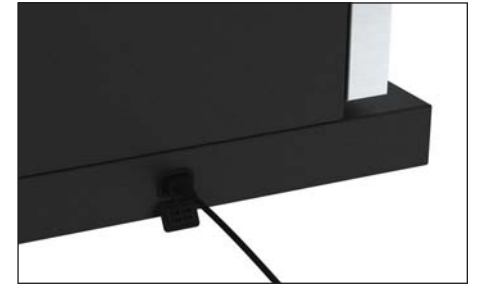

Removable Power Cord

The Fuego O2 Electric has a removable and weather proof power cord, which can be easily stored in one of its compartments when not in use.

Expand your social network with the right connections

Equal parts modernist dreamscape and culinary powerhouse, Fuego Modular is an easy-to-customize outdoor kitchen that dishes up entertaining at its best. Individual stainless steel modules can be configured any way you want. Being the envy of your friends comes separately.



Fuego Modular: Enjoy Mass Appeal

Fuego Modular comes with everything but four walls and a roof and can be configured either freestanding or mounted. Here in one streamlined piece of modernism, you can grill, warm, stash, chill and wash.



Design to your preference.
Mix and match each
pre-assembled module to
meet your cooking needs.



Basalt countertops and
15" round stainless steel sink
and faucet are perfect
for full scale entertaining.

Stools not included.
Templates available for
custom countertops.

Storage Unit

Underneath an eye-catching expanse of teak is a heavy-duty cabinet big enough to house a propane tank or everything from our grill unit's interchangeable drawers to the makings of a perfect margarita.

Utility Unit

Want a refrigerator? A sink system? A wine cooler? A really roomy space for storing essentials? With our Utility Unit, the options are yours.

Modular Accessory System

Geometric slots in the stainless steel side panels provide the ultimate in functionality, allowing you to peg optional accessories such as trays, spice racks and more.



Light Unit

An aluminum light unit with directional halogen bulbs, lets you see—and be seen.

Cook Unit

A two-burner cook-top unit with a roomy storage area below makes running to the kitchen to stir the pot or grab a utensil nothing short of obsolete.

Warm Unit

Our warm unit lives up to its name. Underneath a slate countertop, separate compartments keep food at a toasty temperature until you're ready to serve.

Grill Unit w/ Infrared interchangeable drawer*

The Grill Unit with infrared drawer emulates the heat of charcoal and speed of gas in one efficient system which sears to perfection.

Grill Unit w/ Gas interchangeable drawer*

Our Grill Unit with interchangeable gas drawer boasts 18,500 BTUs to tackle whatever you toss its way.

*Interchange charcoal drawer available as option.

Fuego Modular: Imagine the Possibilities

Know what it's like to get everything you've always wanted all at once? Don't worry. You will.

Features

Commercial-grade stainless steel pre-assembled modules with self closing cabinets and black powder coated interior

Storage unit with teak countertop, and room to store an LP tank or (2) interchangeable drawers

Grill unit w/ Gas Drawer, Interchangeable with patented drawer system. 18,500 btu/hr and 4" cooking lid

Grill unit w/ Infrared Drawer, Interchangeable with patented drawer system. 18,500 btu/hr and 4" cooking lid

Cook unit with dual 12,000 btu/hr sealed burners, and lower storage drawer

Warm unit with slate countertop, sterno fueled warming drawer and (4) chafing pans with lids

Utility Unit with (2) 24" stainless steel cabinets. Can be replaced with 24" refrigeration as option. Modular Accessory System side panels

Cast iron grill grates

Stainless steel residue trays

Battery ignition per module (batteries included)

Basalt stone dining countertop

Basalt stone utility unit countertop w/ stainless steel 15" round sink/ faucet

Aluminum light unit, 120 volts with directional halogen lights

Standard with natural gas connections, LP conversion kit available as accessory

Accessories (sold separately)

Charcoal Interchangeable Drawer

Infrared Interchangeable Drawer

Gas Interchangeable Drawer

Paper Towel Holder

Ceramic Tray Set

Spice Accessory Jars

Beverage Bucket

Griddle/ Flat Plate

7" Large Cooking Lid

LP Conversion Kit

Outdoor Cover

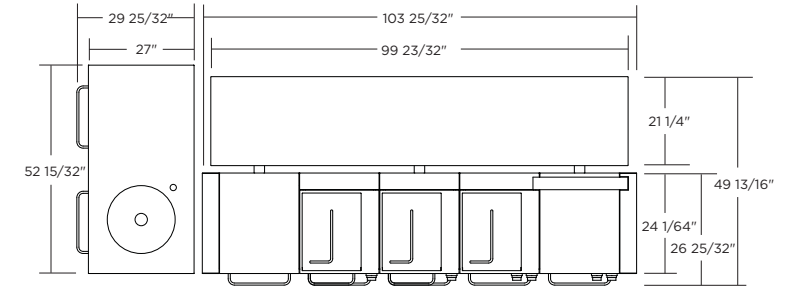

Top

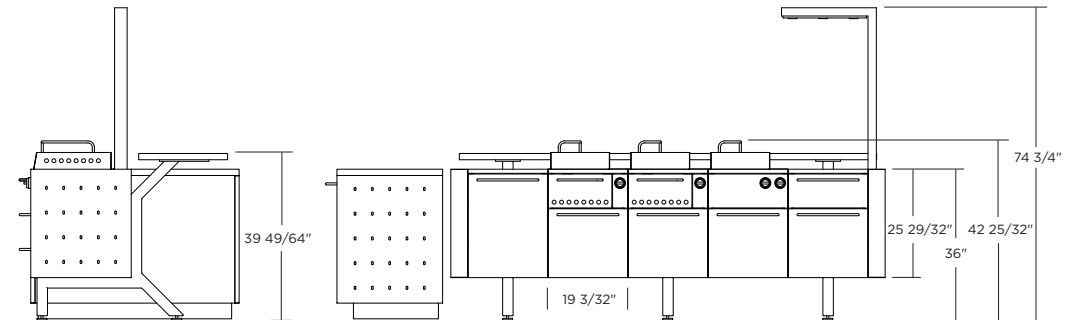

Side

Front

Specifications are subject to change without notice. Please call 888.88.FUEGO or check our website at www.fuegoliving.com for potential specification updates.

Accessory System

To spare you from having to dash into the kitchen at inopportune times—say, you’re in the middle of a mojito—all Fuegos come with optional accessories that peg onto stainless steel side panels, keeping cooking essentials close at hand.

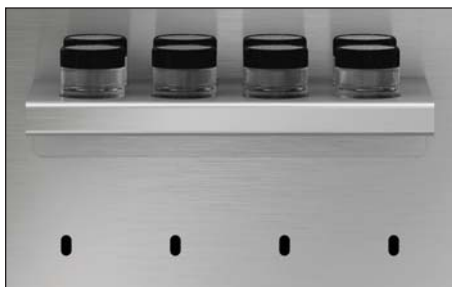

Spice/Accessory Jars and Rack

Adding a pinch of this and a sprinkle of that is easy with jars that can be filled with herbs, spices or other culinary must-haves.



Paper Towel Holder

Wipe up mishaps in a flash with quick-to-reach paper towels.



Large Cooking Lid

A 7-inch cooking lid is available for chefs who prefer to do their grilling undercover.



Beverage Bucket

While some may say that a beverage bucket is not a grilling essential, our experience strongly suggests otherwise.



Flat Plate

An enamel-coated, cast iron griddle lets the grill top do double-duty as a cook top.



Ceramic Tray Set

Two sturdy ceramic trays are just the place to hold everything from kabobs to utensils.



Fuego Industrial Designer Robert Brunner

Robert Brunner is famous for challenging the status quo with designs that are fresh and unexpected. His Fuego grill is no exception. Brunner, whose award winning works are included in the permanent collections of the Museum of Modern Art in both New York and San Francisco, is former Director of Design at Apple and partner at internationally renowned Pentagram Design. He is now CEO of Ammunition, a new product design consultancy group focused on keeping innovation red-hot.

There's a lot to be said for playing with fire,
isn't there?



www.fuegoliving.com

FUEGO North America
Roundhouse One
1500 Sansome Street, #100
San Francisco, CA 94111
1.888.88.FUEGO